

Simultaneous control of the motion and stiffness of redundant closed-loop link mechanisms with elastic elements[†]

Nobuyuki Iwatsuki^{1,*}, Takanori Kotte² and Koichi Morikawa¹¹Department of Mechanical Sciences and Engineering, Tokyo Institute of Technology, Meguro-ku, Tokyo 152-8552, Japan²Toshiba Corporation, Minato-ku, Tokyo 105-8001, Japan

(Manuscript Received May 3, 2009, Revised October 24, 2009; Accepted October 30, 2009)

Abstract

This paper describes the position and stiffness control of planar redundant link mechanisms with elastic elements in order to utilize the flexibility of robots. Assigning both of the two-dimensional position and stiffness of an output link as an output vector, the procedure of the forward kineto-static analysis for the planar redundant link mechanisms with elastic elements is formulated. The mechanisms have elastic linearactuators composed of a coil spring and linearactuator and rotary actuators and multi jointed links. An inverse kineto-static analysis to obtain the optimum input motions which can generate the desired position and stiffness of the output link while taking into account the motion range of the linearactuator is also conducted and applied to the optimum motion control of the mechanism. Several simulations and experiments with a prototype of a planar closed-loop manipulator with 5 DOF and 4 output show the effectiveness of the proposed method.

Keywords: Link mechanism; Elastic element; Stiffness; Inverse kinematics; Forward kinematics; Force balance; Motion control; Redundant DOF; Gradient projection method

1. Introduction

In the development of high-performance robots which can work in human daily life, it is strongly required that these robots be endowed with controllable flexibility. Conventional methods that give robots flexibility are divided into active compliance [1]/impedance [2] control and passive control [3] by adding elastic elements to robots. The former method needs many sensors and does not obtain high response.

In this paper, the authors attempted to realize noble passive compliance in robots using the latter method. A new closed-loop link mechanism with elastic elements and redundancy was proposed and controlled [3]. In this research, the absolute value of output stiffness was set as an objective function, and the optimum joint input to maximize the objective function while generating the desired motion was calculated. However, the value of stiffness could not be specified.

Thus, in this paper, we propose a new concept to simultaneously control both output motion and stiffness of closed-loop link mechanisms with elastic elements. As an example,

the concept is applied to a planar link mechanism with elastic linearactuators and 5 DOF, and its motion and stiffness control is theoretically and experimentally examined.

2. Link mechanism with elastic elements

2.1 Closed-loop elastic mechanism with 5 DOF

In order to control both two-dimensional displacement and stiffness of the output link while utilizing the redundancy of the mechanism, a planar link mechanism with 5 DOF as shown in Fig. 1 was synthesized. In this mechanism, an output link, $J_4J_5J_6$ is connected with three elastic linearactuators, each of which is composed of a linearactuator and a coil spring attached at the tip of the linearactuator. One of the elastic linearactuators is connected with a frame with a revolute pair, while the others are connected with link arms driven by rotary actuators. By driving five actuators, two-dimensional vectors of displacement, $P(x_p, y_p)$, and stiffness, $K(K_x, K_y)$, can be controlled.

2.2 Kinematics

The position vectors of the revolute joints in the mechanism can be represented as

[†] This paper was presented at the ICMDT 2009, Jeju, Korea, June 2009. This paper was recommended for publication in revised form by Guest Editors Sung-Lim Ko, Keiichi Watanuki.

*Corresponding author. Tel.: +81 3 5734 2538, Fax.: +81 3 5734 3917

E-mail address: nob@mep.titech.ac.jp

© KSME & Springer 2010

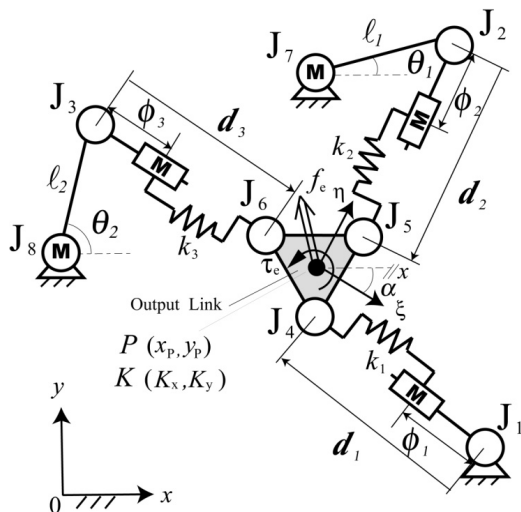

Fig. 1. A closed-loop link mechanism with elastic elements and 5DOF.

$$J_i = \begin{cases} \begin{bmatrix} l_{i-1} \cos \theta_{i-1} + x_{i+5} \\ l_{i-1} \sin \theta_{i-1} + y_{i+5} \end{bmatrix}, & (i = 2, 3) \\ \begin{bmatrix} \cos \alpha & -\sin \alpha \\ \sin \alpha & \cos \alpha \end{bmatrix} \begin{bmatrix} \xi_{i-3} \\ \eta_{i-3} \end{bmatrix} + \begin{bmatrix} x_p \\ y_p \end{bmatrix}, & (i = 4, 5, 6) \end{cases} \quad (1)$$

where (x_i, y_i) ($i=1 \sim 8$) are the coordinates of the joints on the frame, (x_p, y_p, α) is the position and posture angle of the output link, (ξ, η) are the coordinates of joints on the moving system, and l_i denotes link length, and θ_1, θ_2 are the rotary actuators.

The direction vectors of elastic linearactuators can be written as

$$d_i = \begin{bmatrix} d_{ix} \\ d_{iy} \end{bmatrix} = \begin{bmatrix} \cos \alpha & -\sin \alpha \\ \sin \alpha & \cos \alpha \end{bmatrix} \begin{bmatrix} \xi_{i-3} \\ \eta_{i-3} \end{bmatrix} + \begin{bmatrix} x_p - x_i \\ y_p - y_i \end{bmatrix} \quad (2)$$

3. Forward Kineto-static analysis

3.1 Force balance equation

The reaction force of coil spring in the elastic linearactuator can be written as

$$K_x = -\sum_{i=1}^3 k_i \frac{d_{ix}^2}{|d_i|^2}, \quad K_y = -\sum_{i=1}^3 k_i \frac{d_{iy}^2}{|d_i|^2}, \quad (3)$$

$$K_{xy} = K_{yx} = -\sum_{i=1}^3 k_i \frac{d_{ix} d_{iy}}{|d_i|^2}$$

where ϕ_i and δ_i are the output displacement of the linearactuator and the elastic deformation of the coil spring, respectively. Further, $\Psi = (x_p, y_p, \alpha, \theta_1, \theta_2)^T$ denotes the configuration determination parameters [3] which represent the position and posture of all links. The reaction force of the coil spring can be calculated with the displacement of revolute joints.

The force balance equations on the output link subjected to external force, f_e , and moment, τ_e , acting on point P on the link are derived as

$$\begin{cases} \sum_{i=1}^3 f_i + f_e = 0 \\ \sum_{i=1}^3 (J_{i+3} - P) \times f_i + \tau_e = 0 \end{cases} \quad (4)$$

By giving actuator inputs (ϕ_i, θ_j) and setting as $f_e = 0, \tau_e = 0$ in Eq. (4), the displacement of the output link, (x_p, y_p, α) , can be solved with the Newton-Raphson method, and the configuration determination parameters, Ψ , can be determined.

3.2 Output stiffness

When the output point P is located at $(x_{p,0}, y_{p,0})$, maintaining force balance, then the point moves to (x_p, y_p) due to external force. The elastic displacement of the output point due to external force is written as

$$\Delta = \begin{bmatrix} \Delta_x \\ \Delta_y \end{bmatrix} = \begin{bmatrix} x_p - x_{p,0} \\ y_p - y_{p,0} \end{bmatrix} \quad (5)$$

In this case, the external force, f_e , can be represented by the elastic displacement, Δ , as

$$f_e = -\sum_{i=1}^3 k_i \left(1 - \frac{|d_i|}{|d_i + \Delta|} \right) (d_i + \Delta) \quad (6)$$

By partially differentiating Eq. (6) and then setting $\Delta = 0$, the stiffness matrix of the output link at balanced situation can be derived as

$$f_e = K \Delta, \quad K = \begin{bmatrix} K_{xx} & K_{xy} \\ K_{yx} & K_{yy} \end{bmatrix}, \quad (7)$$

where

$$K_x = -\sum_{i=1}^3 k_i \frac{d_{ix}^2}{|d_i|^2}, \quad K_y = -\sum_{i=1}^3 k_i \frac{d_{iy}^2}{|d_i|^2}, \quad (8)$$

$$K_{xy} = K_{yx} = -\sum_{i=1}^3 k_i \frac{d_{ix} d_{iy}}{|d_i|^2}$$

After solving the configuration determination parameters, the two-dimensional output stiffness, (K_x, K_y) , can be calculated.

4. Inverse Kineto-static analysis

4.1 Condition in output stiffness

To obtain the actuator input, (ϕ_i, θ_j) , and to generate the de-

sired output displacement and stiffness, (K_x, K_y) , the following procedure was proposed.

First, the rotary actuator inputs, θ_1, θ_2 , and the posture of output link, α , are calculated with Eq. (8). By partially differentiating Eq. (8) with respect to θ_1, θ_2 and α , the following system of linear equations can be obtained:

$$\begin{bmatrix} \Delta K_x \\ \Delta K_y \end{bmatrix} = \mathbf{C} \begin{bmatrix} \Delta \theta_1 \\ \Delta \theta_2 \\ \Delta \alpha \end{bmatrix}, \quad \mathbf{C} = \begin{bmatrix} \frac{\partial K_x}{\partial \theta_1} & \frac{\partial K_x}{\partial \theta_2} & \frac{\partial K_x}{\partial \alpha} \\ \frac{\partial K_y}{\partial \theta_1} & \frac{\partial K_y}{\partial \theta_2} & \frac{\partial K_y}{\partial \alpha} \end{bmatrix} \quad (9)$$

By using the pseudo-inverse of matrix, \mathbf{C} , the general solution for Eq. (9) can be given as

$$\begin{bmatrix} \Delta \theta_1 \\ \Delta \theta_2 \\ \Delta \alpha \end{bmatrix} = \mathbf{C}^\# \begin{bmatrix} \Delta K_x \\ \Delta K_y \end{bmatrix} + (\mathbf{I} - \mathbf{C}^\# \mathbf{C}) \boldsymbol{\varepsilon}, \quad (10)$$

where $\mathbf{C}^\# = \mathbf{C}^T (\mathbf{C} \mathbf{C}^T)^{-1}$ and $\boldsymbol{\varepsilon}$ is an arbitrary three-dimensional vector.

By setting $\boldsymbol{\varepsilon}$ as the partial differentiation of objective function with respect to θ_1, θ_2 and α , an optimum solution to utilize redundant DOF can be obtained with the gradient projection method. For example, to increase the movable range of linearactuators, the following vector is given:

$$\boldsymbol{\varepsilon} = \begin{bmatrix} \sum_{i=1}^3 \frac{\partial \left[|d_i| - (\phi_i + \delta_i) \right]^2}{\partial \theta_1} \\ \sum_{i=1}^3 \frac{\partial \left[|d_i| - (\phi_i + \delta_i) \right]^2}{\partial \theta_2} \\ \sum_{i=1}^3 \frac{\partial \left[|d_i| - (\phi_i + \delta_i) \right]^2}{\partial \alpha} \end{bmatrix} \quad (11)$$

4.2 Condition on output displacement

After calculating θ_1, θ_2 and α , the linearactuator input, ϕ_i , can be calculated with Eq. (4) by using the Newton-Raphson method, which is used in the forward kineto-static analysis. Resultantly all actuator inputs can be determined.

5. Experimental validation

5.1 Prototype

Fig. 2 shows the prototype of a closed-loop link mechanism with elastic elements and 5 DOF. Each elastic linearactuator is composed of a DC rotary motor, a ball screw, a linearguide and a coil spring as shown in Fig. 3. The principal dimensions and spring properties are listed in Table 1. To measure the displacement of output point, two rotary encoders and a linear potentiometer are mounted on revolute joints J_1, J_4 and on coil springs, respectively.

Table 1. Dimensions of the prototype and spring property.

Fixed joint [mm]		Moving joint [mm]	
(x_1, y_1)	(0,0)	(ξ_1, η_1)	(0,60)
(x_7, y_7)	(428.5,565.0)	(ξ_2, η_2)	(60,30)
(x_8, y_8)	(-428.5,565.0)	(ξ_3, η_3)	(30,60)
Link length [mm]			
ℓ_1	220	ℓ_2	220
Spring Constant [N/mm]		Natural Length [mm]	
k_1	0.8255	δ_1	94.0
k_2	0.8047	δ_2	87.5
k_3	0.7917	δ_3	87.5

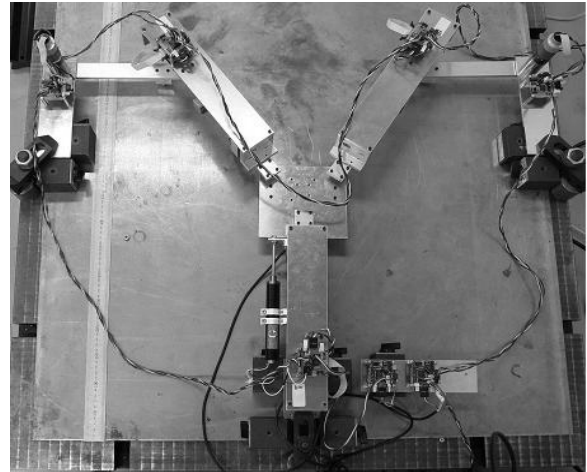

Fig. 2. Prototype of a closed-loop link mechanism with elastic elements and 5DOF.

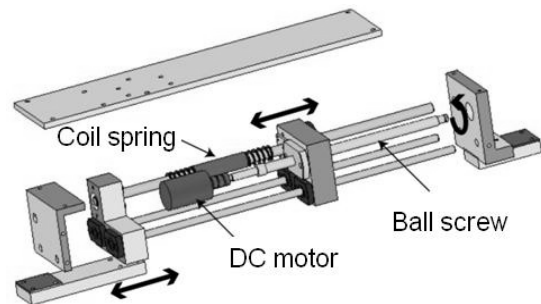

Fig. 3. An elastic linearactuator.

5.2 Experimental results

Fig. 4 shows one example of the measured output displacement in a case where circular motion and the constant stiffness, $(K_x, K_y) = (0.8, 1.8)$, are specified as the desired values. It is confirmed that the mechanism can generate the desired trajectory, while there exists some errors in the x -direction. Fig. 5 shows the relation between elastic displacement and external force at four positions on the circular trajectory, which are measured with a micrometer and a force gauge. It is also confirmed that the mechanism can generate the desired stiffness.

Table 2. Experimental results for stiffness control.

Stiff. Ptn.	Desired (K_x, K_y)	Measured (K_x, K_y)	Measured (x_p, y_p)	α
a	(1.60, 0.80)	(1.46, 0.77)	(-17.5, 348.2)	93.2
b	(1.20, 1.20)	(1.18, 1.05)	(-18.5, 356.3)	78.2
c	(0.80, 1.60)	(0.79, 1.40)	(-17.6, 350.0)	62.5
d	(2.00, 0.40)	(0.42, 1.92)	(-16.3, 351.2)	17.7

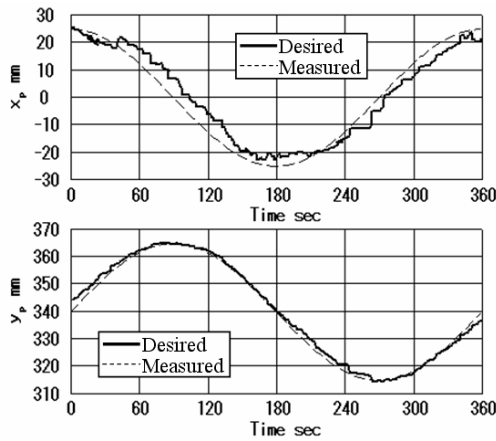

Fig. 4. Measured displacement when circular motion is given.

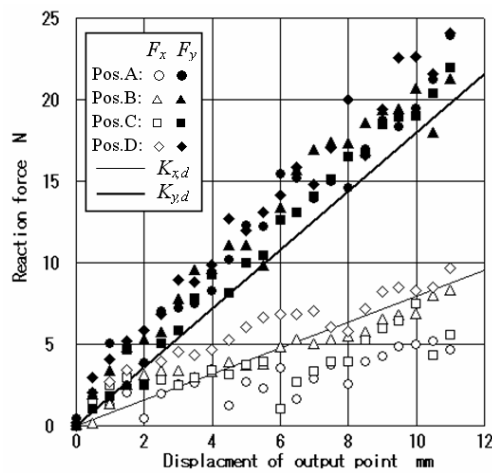

Fig. 5. Measured elastic displacement and reaction force.

Then the constant output point displacement, (-20, 350), and various desired stiffness vectors are specified. The experimental results are listed in Table 2. While there exists about 15% error in the measured stiffness, the mechanism generates the desired output displacement with various posture angles. It is thus confirmed that the mechanism can generate the required stiffness by utilizing redundant DOF and that the proposed control method is effective and useful.

6. Conclusions

The motion and stiffness control of a redundant closed-loop mechanism with elastic elements are proposed and theoretically and experimentally examined. The obtained results are

summarized as follows:

- (1) Based on the balance of reaction forces of elastic linearactuators, the output stiffness of the closed-loop mechanism with 5DOF was derived.
- (2) A new inverse kineto-static analysis by using the gradient projection method with an objective function on a movable range of linearactuators was proposed and formulated.
- (3) A prototype could generate both the desired motion and stiffness with the proposed control method.

References

- [1] B. H. Kim and et.al., Independent finger and independent joint-based compliance control of multifingered robot hands, *IEEE Trans on Robotics and Automation*, 19 (2) (2003) 185-199 .
- [2] G. Ferretti, G. Magnani and P. Rocco, Impedance control for elastic joints industrial manipulators, *IEEE Trans on Robotics and Automation*, 20 (3) (2004) 488-498.
- [3] N. Iwatsuki, T. Kitamura, T. Miura, I. Hayashi and K. Morikawa, Kinematic analysis of planar network-structure robots with elastic elements, *CD-ROM Proc. of the 3rd China-Japan Symposium on Mechatronics*, (2002), 1-6.
- [4] N. Iwatsuki, T. Kotte and K. Morikawa, Control of output motion and stiffness of multi-DOF linkage with elastic elements, *Proc. of the JSME Symposium on Motion and Power Transmissions 2007*, (2007) 202-205 (in Japanese).



Nobuyuki Iwatsuki received his PhD in Mechanical Engineering from Tokyo Institute of Technology, Japan in 1987. He is currently a Professor at the Department of Mechanical Sciences and Engineering, Tokyo Institute of Technology. His research interests include robotics, silent engineering and laser

measurement.

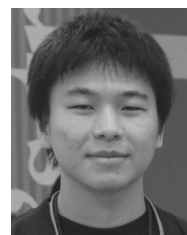

Takanori Kotte received his Master's degree in Mechanical Sciences and Engineering from Tokyo Institute of Technology, Japan in 2007. He is currently an engineer at Toshiba Corporation. His research interests include robotics and design engineering

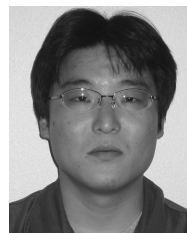

Koichi Morikawa received his Master's degree in Mechanical Engineering for Production from Tokyo Institute of Technology, Japan in 1996. He is currently an Assistant Professor at the Department of Mechanical Sciences and Engineering, Tokyo Institute of Technology. His research interests include silent engineering, laser measurement.

silent engineering, laser measurement.